

# GO-LINE 30 USER GUIDE AND MANUAL

## South African Model

The Go-Line 30 marker is a robust modern line marking machine designed to make the marking of lines on grass and artificial surfaces easy. Correct use of the machine will provide the best results. This section provides a guide as to how to achieve the best results when using the Go-Line 30 machine.

### How to use the Go-Line 30:

#### **How to mark lines with Go-Line 30 machine:**

1. Filling the 28 litre line marking tank with marking liquid. It is recommended that only sufficient marking liquid is put in the tank to cover the area to be lined. Follow marking liquid mixing instructions prior to filling the tank. As a guide between 1 and 1.5 litres of mixed marking liquid will mark 100 linear meters. This is variable depending on speed of travel. **Note.** A damaged nozzle can significantly increase the volume output. Reduced battery power or partially blocked filters can reduce volume output. (Mix the marking liquid in line with the instructions shown below in section C)
2. Fill the water cleaning tank with 1.75 litres of clean water.
3. Turn the Marking Liquid/Water handle on the console to the Marking Liquid position
4. Set the discs to the required width and secure them in position. Adjust the height of the nozzle so the nozzle's fan edge impacts the disc between 3 and 5mm from the bottom of the discs.
5. *It may be necessary to purge air from the line to start marking liquid flow. This can be done in two ways. Either by unscrewing the DCV red cap half a turn or removing the nozzle and cap. Switch the machine on and once marking liquid flow is achieved switch off and either retighten the DCV cap or put the nozzle and cap back in place.*
6. Once the line width has been set the task of marking the sports surface is simple. Place the machine's nozzle at the point the line is to start. If there is a string that has been placed to follow, address the machine in relation to the string. It is recommended that the string should be lined up with the edge of the spray fan. If the discs are being used, line up the string with the inside or outside edge of either the left or right disc. To commence the line marking operation, switch the machine on at the On/Off switch on the handlebar and push along the line to be marked. Be sure to move forward when switching on. At the point the line is to be stopped, switch off the machine. Go-Line 30 is designed to go

around corners as well as straight lines so semi circles on soccer fields are easy. For very tight semi circles, such as soccer corners, simply lift up the rear wheels and pivot the machine on its front wheels. If the front disc set is in use the discs should be lifted up into the transport position to allow for the required tight turn.

It is important once the line marking work has been finished, the machine is cleaned. Cleaning is simple as the Go-Line 30 has a secondary clean water tank and an easy empty point at the bottom of the main tank. See Machine Maintenance Cleaning after use section page 4.

## **Ways to optimize line quality**

### **Line marking liquids - Storage and use:**

Consult your Go-Line 30 supplier for their recommendation on appropriate line marking liquids. Always store line marking liquids in a secure place away from children, animals and free from frost. Water based line marking liquids can be damaged by frost and may become unusable. Always use GO MARK line marking liquid which has been specifically designed for use with a spray type line marker. **Use of other liquids may damage the pump, foul lines and will render the guarantee invalid. Never use PVA, enamels, diesel, lime or solvent based products in the machine.**

Stay within the dilution guidelines shown on the marking liquid container. Using line marking liquids outside of their recommendations will result in poor line quality and/or blockages in the pump or spray lines. Lower dilution rates will generally provide brighter, whiter lines.

### **How to achieve best results in use:**

#### ***A. The surface***

1. Always try to find the best possible weather window for the task of line marking. No line marking liquid will be as effective when sprayed on in wet weather or onto a wet or damp surface. If sprayed in rainy conditions performance of the marking liquid will be effected and can in severe cases be completely washed away before it can dry.
2. Line marking liquid will perform best on surfaces that have good grass quality and density. Generally results will be poorer on areas of sparse or no grass cover. In the case of artificial grass surfaces, the surface manufacturer should be consulted for compatibility of the line marking liquid with the surface.

3. The surface should always be mowed and the grass length uniform before the area is line marked. Any excessive amounts of grass clippings or other debris such as leaves should be removed from the line area prior to marking.

#### ***B. The line marking liquid***

1. Mix the line marking liquid immediately prior to use and insure it is thoroughly mixed with clean water.
2. Make sure the vessel used for mixing the marking liquid is clean and free from dirt and debris.
3. When mixing marking liquid a dedicated mixing drum that can be vigorously shaken to insure the concentrate and water are homogenous throughout is a sure way of achieving a good mix. Alternatively a bucket and mixing stick can be used; a flat paddle type stick is preferable. All mixing vessels should be cleaned after use.
4. If on completion of the line marking task there is marking liquid remaining in the Go-Line 30 tank the marking liquid can either be removed via the tank drain plug, or via the nozzle. For best results remove marking liquid and wash through the tank with clean water to ensure it remains clean and free of any build up.
5. Marking liquid as described in 4 above can be stored and reused at a later date. Before reusing it make sure that this marking liquid is thoroughly remixed. If marking liquid has been left in the tank for later use it can be remixed by rocking the machine forwards and backwards on the back wheels. The baffles in the tank assist in the agitation and so remixing of the marking liquid is achieved in a homogenous manner.

#### ***C. The Machine***

1. Always make sure the machine's pipe work, nozzle and filters (x2) are clean prior to use and the battery is fully charged.
2. The spray nozzle should be in pristine condition. For best results spray nozzles should be replaced regularly. A damaged spray nozzle will significantly impact line quality. Spray nozzle damaged can be seen by distortion of the fan when spraying, and possible non uniform appearance of the line itself. Replacement nozzles should be as specified in the machine manual. Ask your Go-Line 30 supplier about replacement nozzles.
3. The disc system is a further aid to line quality. When using the disc system the correct setting up is a significant factor in achieving optimum line quality. The discs need to be set up so the nozzles fan edge impacts the disc between 3 and 5mm from the bottom of the discs.

4. Make sure all tyres are inflated and are of a uniform pressure. Over inflation of tyres makes the machine less stable, under inflation makes using the machine more strenuous.

#### ***D. The Operator***

1. The machine is designed for a comfortable to brisk walking speed. It is important to travel at a constant speed.
2. The machine provides different positions to spray from. The “in front position” and the position on either side. (the side mounting system is an optional extra – consult your Go-Line 30 agent) To keep lines straight when over marking an area, and not using a string as a guide, it is important to have the machine handlebar height set up in the way that feels most comfortable for the individual. It is generally found easier when using the “in front” nozzle position that the user walks to one side of the line straddling it.
3. Before using the machine for the first time it is recommended that the user practices line marking operation in order to familiarize themselves with the use of the machine.

## **Machine Maintenance**

### **Cleaning after use:**

1. Once the line marking task is complete turn the line Marking Liquid/Water handle on the console to the Water position. Switch the machine on at the handlebar and run for 30 to 45 seconds. Switch off the power. The pipe work, nozzle and filters on the Go-Line 30 are now clean.  
If the Go-Line 30 is not going to be used within 24 hours, any mixed marking liquid should be removed from the tank. This can be achieved in two ways, either spray the product that remains in the tank out through the nozzle into a collecting vessel, (For speed remove the nozzle tip and filter) or empty through the drain plug at the rear of the machine. If it is chosen to empty the machine through the spray nozzle, spray contents into a collecting vessel then switch off the machine. Turn the marking Liquid/Water valve on the console to the water position. Switch on the machine at the handlebar switch and let the machine run for 30 to 45 seconds.
2. If it is chosen to empty the machine via the drain plug, place a collecting tray/vessel under the tank drain plug and remove the plug by unscrewing and pulling it downwards, so allowing the contents of the tank to flow out. To aid drain plug emptying tip the Go-Line 30 onto its back wheels.

3. Once all marking liquid is drained out it is recommended that a high pressure hose is sprayed inside the tank allowing water to drain out through the drain plug. This is the optimum method of removing any residue ensures that the tank baffles and tank interior is kept clean. Use a suitable area for disposal of these washings. Once clean push back in place the drain plug and screw until tight.
4. The regular use of a “GO-FLUSH” to keep the machine pipe work clean and pump free of blockages is recommended. Consult your supplier for recommendations. A measured amount of GO-FLUSH can be added to the clean water tank. This will improve cleaning of the pipes, filters, nozzles and lubricate the pump parts. GO-FLUSH will not harm turf.
5. Check that all filters are clean. The tip filter behind the nozzle may need cleaning. The in-line filter located under the rear of the machine should periodically be checked for debris build up. To clean unscrew the filter cap remove the gauze and clean thoroughly in soapy water. After cleaning relocate gauze and screw the cap back on.

### **Monthly maintenance**

It is recommended that the main marking liquid tank is washed out monthly. This is to prevent an excessive build up in the bottom of the tank. Choose a suitable area for cleaning and remove the tank bung at the rear of the machine. To remove, unscrew and pull out the drain plug. To relocate push the drain plug back in and tighten. To wash through the tank, simply remove the cap and using a hose pipe, flush water at pressure into and through the tank. These washings will then exit the drain hole at the rear of the tank. Wash through until thoroughly clean and then replace the drain plug into the rear tank drain hole. Replace tank cap. To use GO-FLUSH will assist in removing marking liquid residue from the parts and tank.

### **Long term maintenance**

The battery should be fully recharged over night after use. When the machine is not being used the battery should be recharged every 2 weeks to keep it in optimum condition. Leaving a battery for a period in excess of 3 months can permanently damage the battery and reduce its life span. *Please note the battery is not covered under the machine guarantee.*

The pump should be preferably left with clean water and GO FLUSH in the system, this prevents the pump diaphragms from getting dry and brittle over time.

The machine should be stored inside and away from frost.

Replace the nozzle at the start of each new season, replace filters and filter gauzes as and when required.

Tyres should be inflated as required.



## General information

### Battery:

The battery supplied with the machine is a 12V 17AH dry sell battery. When the battery is fully charged it should operate the pump for  $\pm 8$  hours of constant run time. To maximize battery life it is important that the battery is fully charged before first use and then recharged after each use. To fully charge the battery it should be charged for 12 to 16 hours. To recharge the battery simply plug in the charger to the recharge point on the console of the machine, plug into the mains electricity and switch on. After charging switch off and disconnect charger.

### Charger:

The charger supplied is designed to recharge the battery in maximum time of 16 hours. After charging, the charger should be switched off and disconnected from the mains. In event the charger does not work, ensure the electricity supply is on. The charger must never come in contact with liquids.

### Pump:

The pump is a 3 chamber positive displacement pump complete with a pressure sensing demand switch, which controls the maximum operative pressure. The demand switch allows the Go-Line 30 to be effective for hand stencil work and also prevents pump damage in the unlikely event of a blockage. It is a serviceable pump with limited built in dry run protection. (Consult your Go-Line 30 agent on spares and services)

### Spares available:

1. Lower Housing – GL7018
2. Valve Housing – GL7019
3. Upper Housing – GL7020

### Replacement Parts

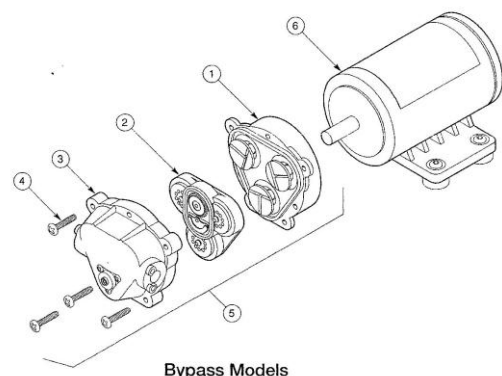

**Do not pump GASOLINE or other FLAMMABLE liquids. Pump head materials are designed for use with water only. Use of any liquids other than those specified for the GO LINE 30 machine will void the guarantee.**

## Specifications South African Model

Box size	870 mm X 530 mm X 470mm
Height	43 cm (handlebar not included)
Length	101 cm (front marking machine not included)
Machine weight	23 Kg empty including battery
Tank sizes	28 litres + 1.75 litre wash tank
Wheels	260 X 85 treaded with inner tube
Axles and handlebars	Zinc electroplated and blue passivated. Coated areas black ferrograin powder coat
Nozzle	Yellow F80-02
Tip Filter	50 mesh
In line strainer	Polypropylene bowl filter type.
Battery	Standard 17AH – 12 Volt
Charger	5 Amp Switch model Power Supply – 12VDC.
Pallet quantity	8 units
Hose and fittings	Clear 8mm thick wall piping / brass fittings

## Go-Line 30 Accessories

### Disc System-(Standard with South African Model)

The technically advanced disc system is easy to fit, robust and provides an edge to line quality. The disc allows for line quality to be optimized. The two discs by riding with the contour of the ground and the spray head spraying between them provides a constant line width. The effect of the marking liquid touching the lower part of the disc allows for a greater volume of marking liquid to be placed on the edge of the line. The effect of this being the line looks stronger and brighter because the edge is better defined. The discs are designed so they can be quickly lifted up to their storage position against the tank. This facility enables tight circles to be marked. The discs should be kept in the storage position when the machine is being transported on a vehicle or being pushed over hard or difficult surfaces. To change the width of the discs loosen the two hand wheel knobs located on the underside of the disc mounting bar, until the hand wheel knobs are free of their recesses. The disc can then be slid along supporting bar to a different position. For ease of vision when changing the disc width the machine can be sat back on the handlebar. Once the desired width is achieved retighten the hand wheel knobs into the chosen recess.

### Athletics Marker:

The athletic marking machine attachment enables the user to apply three lines and two lanes at the same time to mark out athletics tracks.

### Side spray arm:

The side spray arm allows the operator to easily convert the machine to spray to the left or right side of the machine



Go Line 30 Machine complete with optional Athletics Marking Attachment.

These specifications are issued as a guideline only. Dura Paints reserves the right to make changes without notice.  
Revision: 9 May 2013.